



THE UNIVERSITY OF ALABAMA IN HUNTSVILLE
 PROCUREMENT SERVICES
 301 SPARKMAN DRIVE
 HUNTSVILLE, ALABAMA 35899
 PHONE (256) 824-6484

DATE
 2/07/2011

BID NUMBER
B002042

ALL BIDS WILL BE PUBLICLY OPENED ON THE OPENING DATE DESIGNATED AT THE UNIVERSITY OF ALABAMA IN HUNTSVILLE, PROCUREMENT SERVICES, BUSINESS SERVICES BLDG., HUNTSVILLE, ALABAMA 35899. BIDS RECEIVED AFTER THE SPECIFIED TIME ON THE OPENING DATE WILL NOT BE CONSIDERED.

RESPONSE DUE BY:
 February 22, 2011
 1:30 PM

WHEN USING FEDEX, UPS, OR ANY EXPRESS PACKAGING/SHIPPING, THE BID NUMBER MUST BE CLEARLY PRINTED ON THE AIR BILL.

REQUEST FOR FORMAL BID

CONTACT
 PAMELA HURLEY

PHONE
 256-824-6675

VENDOR NO.
 «vendornum»

V
 E
 N
 D
 O
 R

ALL BIDS MUST BE SIGNED, SEALED, AND RETURNED IN AN ENVELOPE WITH THE BID NUMBER AND OPENING DATE NOTED ON FRONT. FORWARD ALL BIDS TO THE ADDRESS INDICATED ABOVE. FAILURE TO COMPLY WILL RESULT IN A "NO BID" RESPONSE IN ACCORDANCE WITH ALABAMA COMPETITIVE BID LAW 41-16-24 sub-part b.

THE ABOVE BID NUMBER MUST APPEAR ON ALL BIDS AND RELATED CORRESPONDENCE

OR EQUAL, REFER TO GENERAL CONDITIONS ON ATTACHED SHEET

NO	QUANTITY	UNIT	DESCRIPTION	UNIT PRICE	EXTENSION
01			THE UNIVERSITY OF ALABAMA IN HUNTSVILLE REQUESTS A BIDS FOR A FABRICATED BATH AND TEST SKID with LIDS AS PER THE SPECIFICATIONS.		
02			AWARD: NO AWARD INFORMATION WILL BE MADE AVAILABLE BY TELEPHONE, FAX, MAIL, OR EMAIL. ONCE THE BID IS AWARDED, THE AWARD INFORMATION AND TABULATION WILL BE POSTED TO OUR WEBSITE: WWW.UAH.EDU/ADMIN/BUSSVCS/BIDAWARDS.HTM		

SHOULD A PURCHASE ORDER BE ISSUED, THE FOREGOING AND THE TERMS AND CONDITIONS ON THE ATTACHED SHEET SHALL BE APPLICABLE AND BINDING UPON THE VENDOR. I ACKNOWLEDGE THAT I HAVE SIGNATURE AUTHORITY TO SIGN ON BEHALF OF THE COMPANY AND HEREBY AGREE TO ALL GENERAL CONDITIONS OF THIS BID REQUEST.

TOTAL →

SIGNATURE _____
 COMPANY REPRESENTATIVE

DATE _____
 An Affirmative Action/Equal Opportunity Institution

BID PRICES ARE TO INCLUDE ALL SHIPPING CHARGES. (FOB: Destination)

THE UNIVERSITY OF ALABAMA IN HUNTSVILLE RESERVES THE RIGHT TO INCREASE OR DECREASE QUANTITIES ACCORDING TO AVAILABILITY OF FUNDS UNTIL DECEMBER 31, 2011.

DELIVERY MAY BE A FACTOR IN DETERMINING THE AWARD OF THIS BID.
QUOTE EARLIEST POSSIBLE DELIVERY: _____.

THE UNIVERSITY OF ALABAMA IN HUNTSVILLE IS A MEMBER OF THE EDUCATIONAL AND INSTITUTIONAL COOPERATIVE AND IS ENTITLED TO RECEIVE ANY DISCOUNTS OFFERED TO THIS ORGANIZATION.

ANY QUESTIONS PERTAINING TO THIS REQUEST FOR FORMAL BID, PLEASE CONTACT BY EMAIL ALL QUESTIONS TO PAMELA HURLEY AT pkh0002@uah.edu.

THE UNIVERSITY OF ALABAMA IN HUNTSVILLE REQUESTS A BIDS FOR A **FABRICATED BATH AND TEST SKID with LIDS** PER THE SPECIFICATIONS BELOW:

1. Test skid with Lid (30" O.D. x 43") \$_____

Specifications

- Part Numbers: Test Skid: PRC-5093-001 and Test Skid Lid: PRC-5093-002
- 30" O.D. x 43" Face of flange to bottom of vessel test skid with lid.
- Shell is 0.1875" SA-240-304 stainless steel.
- Bottom is 0.625" SA-240-304 stainless steel.
Test skid body flange and test skid lid quoted as 150# flanges with special machining as shown on drawings.
- If 150# RFSO and RFBLD can be used without special o-ring groove machining.

2. Liquid Nitrogen Bath with lid (20 " O.D. x 20") \$_____

Specifications

- Part Numbers: PRC-5093-003 and PRC-5093-004
- 20" O.D. x 20" Face of flange to bottom nitrogen bath with lid.
- Shell is 0.1875" SA-240-304 stainless steel.
- Bottom is 0.75" SA-240-304 stainless steel.
- Nitrogen bath body flange and nitrogen bath lid quoted as 150# RFSO and 150# RFBLD.

See more information below with drawings.

Item: Test Skid and Lid

Description of use: The test Skid will be function as a vacuum chamber for use in a liquid oxygen system. For the lid, ports “C” and “D” will be exposed to liquid oxygen. While the skid should not be exposed to liquid oxygen, it is possible that either conduction through the lid or leakage could lead to the skid’s being exposed to cryogenic temperatures. The operating conditions of the test skid and lid are as follows.

Maximum Pressure: Ambient, Minimum Pressure: Vacuum, (~0 psi), Maximum Temperature: Ambient, Minimum Temperature: -300 F

Due to cryogenic temperatures and oxygen compatibility, the material for the test skid and lid is stainless steel.

Manufacturing Guidelines

Test Skid: In general, the dimensions provided are guidelines and are open to adjustment. However, the internal diameter and height of the test skid may not be decreased buy can be increased to reduce cost. If possible, a standard ANSI flange maybe used for the test skid. For the test skid o-ring, the groove is designed for a -4xx series Parker o-ring. However, the particular o-ring has not yet been determined as that will depend upon the size of the flange. Also, the feet on the test skid should be designed with holes in the feet to provide a method to secure the test skid.

Test Skid Lid: A standard ANSI blind may be used for the test skid lid. The length of ports “C”, “D”, and “G”, can be adjusted. However, “C” and “D” should be designed as FNPT ports on both top and bottom, while “G” needs only to be designed as a FNPT port on top. Features “A”, “B”, “E”, and “F”, will be used with vacuum flanges and will require blind holes for the bolts, Feature “H: will also require blind holes for the bolts. The locations of the features are based off the center of the flange and are filed. The o-ring size and location are fixed. The location of the lift lugs are fixed, but the size is not fixed.

Item: Liquid Nitrogen Bath and Lid

Description of use: the liquid nitrogen bath will be used to condition liquid oxygen passing through the bath. The $\frac{3}{4}$ ” FNPT couplers will serve as the connection ports for the liquid oxygen lines. The liquid nitrogen bath will use a gasket to seal the bath and lid. The operating conditions of the test skid and lid are as follows. Maximum Pressure: 65 psi, Minimum Pressure: Ambient, Maximum Temperature: Ambient, Minimum Temperature: -320 F

Due to cryogenic temperatures the material for the liquid nitrogen bath and lid is stainless steel.

Manufacturing Guidelines

Liquid Nitrogen Bath: In general, the dimensions provided are guidelines and are open to adjustment. Except, the internal diameter and height of the test skid may not be decreased but can be increased to reduce cost. However, the diameter could potentially be reduced if the height is increased. If possible, a standard ANSI flange may be used for the liquid nitrogen bath. The $\frac{3}{4}$ ”FNPT couplers should be designed for FNPT ports on both the inside and outside of the bath. The $\frac{1}{2}$ ” FNPT port needs to have a FNPT port on the outside of the bath. Also, the feet on the liquid nitrogen bath should be designed with holes in the feet to provide a method to secure the bath.

Lid: A standard AMSI blind may be used for the liquid nitrogen bath lid. The height of the FNPT ports can be adjusted. The locations of the features are based off the center of the flange and are fixed. The location of the lift lugs are fixed, but the size is not fixed.

REVISION HISTORY		DATE	APPROVED
REV	DESCRIPTION		

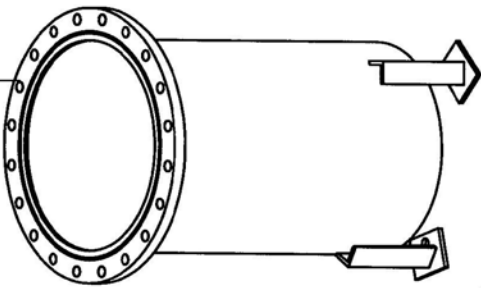

- Notes:
1. Flange Hole Patterns to Match Lid
PIN PRC-5093-002
 2. O-Ring Gasket on Flange for -4XX
O-ring

Material: Stainless Steel

Operating Conditions
 Max Pressure: Ambient
 Min Pressure: Vacuum (~0 psi)

Max Temperature: Ambient
 Min Temperature: -310 F

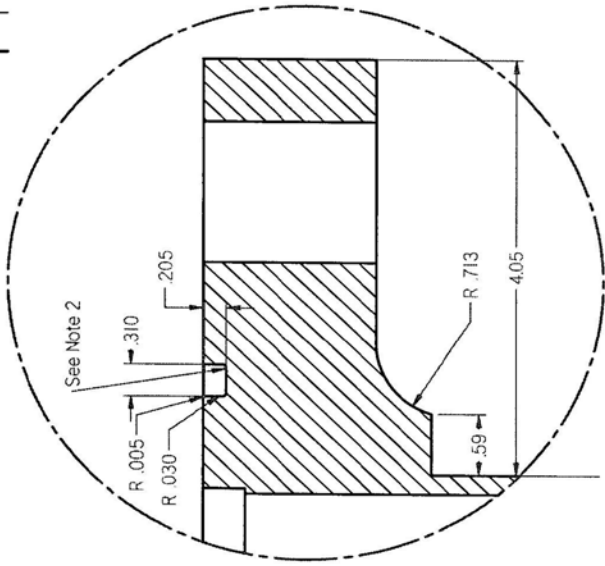

DETAIL B

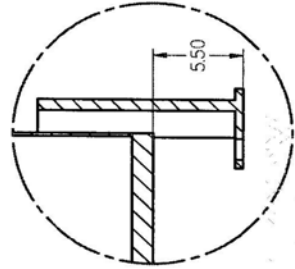

DETAIL C

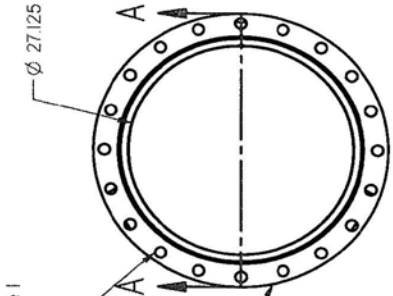

See Note 1
 Flange can be replaced
 with standard ANSI flange

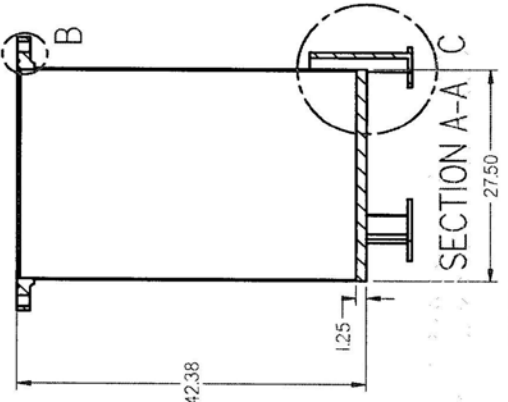

SECTION A-A

SOLID EDGE UGS - The PLM Company		NAME	DATE
DRAWN	M. Hit	10/19/10	
CHECKED			
ENG APPR			
MGR APPR			
TITLE		Test Skid	
UNLESS OTHERWISE SPECIFIED DIMENSIONS ARE IN INCHES ANGLES ±0.5°		SIZE / DWG NO	REV
2 PL ±0.03 3 PL ±0.005		B	PRC-5093-001
SCALE:		FILE NAME: Test-Article-Shell_Update2.dft	
SHEET 1 OF 1		WEIGHT:	

REVISION HISTORY			
REV	DESCRIPTION	DATE	APPROVED

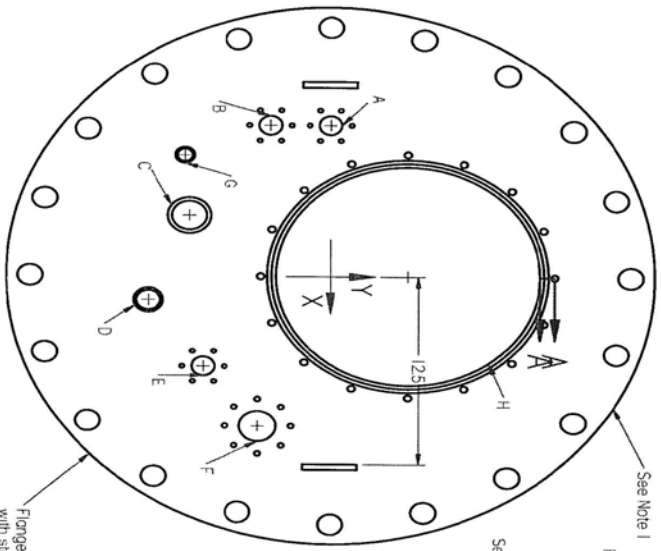
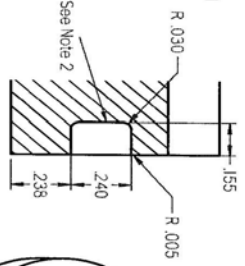
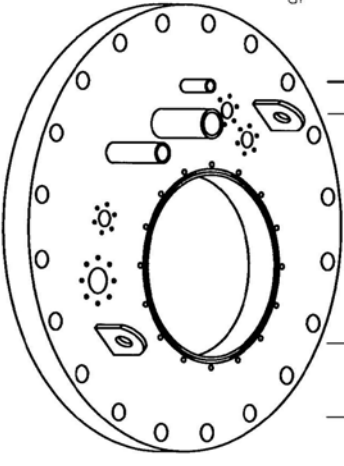

Flange can be replaced with standard ANSI blind

Feature	X	Y	Diameter	# Bolts	Bolt	Bolt Circle Bolt Depth
A	-10	0	1.25	6	.250-28	2.312
B	-10	-3.3	1.25	6	.250-28	2.312
C	-4	-7.75	1-1/2 in FNPT Coupler			
D	1.6	-10	1 in FNPT Coupler			
E	6	-7	1.25	6	.250-28	2.312
F	10	-4	2.00	8	.312-24	3.628
G	-8	-8	1/2 in FNPT Port			
H	0	4.25	14.500	16	.375-24	16.150

Notes:

- 1. Blind Size and hole Pattern to Match Flange PIN PRC-5093-001
- 2. O-Ring Gasket on Blind for -384 O-ring

Material: Stainless Steel

Operating Conditions
 Max Pressure Ambient Min Pressure Vacuum (-0 psi)
 Max Temperature Ambient Min Temperature -310 F

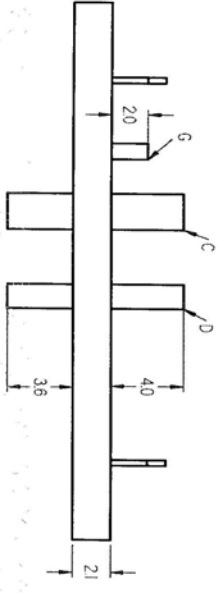

DRAWN	NAME	DATE	SOLID EDGE UGS - The PLM Company Test Skid Lid
CHECKED	M.H.H.	11/12/10	
ENG APPR			
MGR APPR			
UNLESS OTHERWISE SPECIFIED DIMENSIONS ARE IN INCHES ANGLES ±0.1°			SAE DWG NO: PRC-5093-002 FILE NAME: Test-Article-Blind-Top-1.dwg SCALE: WEIGHT: SHEET 1 OF 1

REVISION HISTORY		
REV	DESCRIPTION	DATE

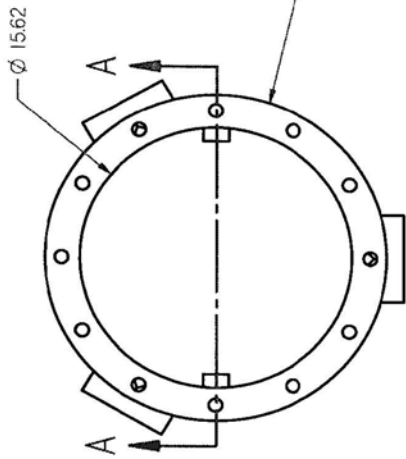

Flange can be replaced with standard ANSI flange See Note 1

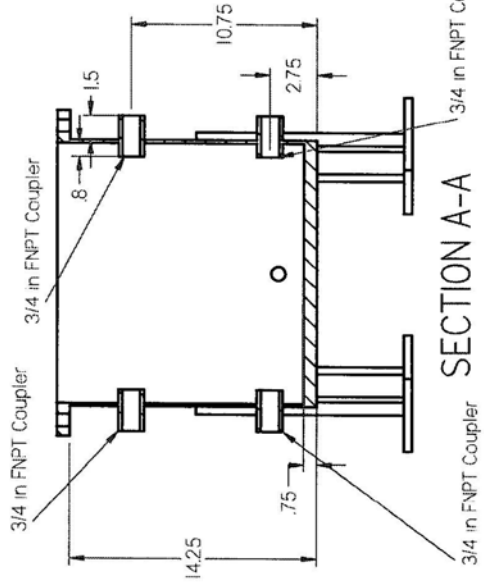
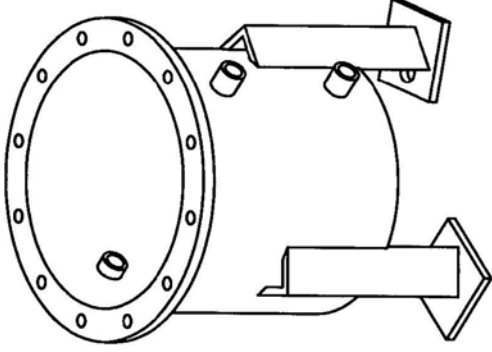

Notes:
1. Flange Hole Pattern To Match Lid PIN
PRC-5093-004

Material: Stainless Steel
Mounting Face Uses Gasket to Seal

Operating Conditions
Max Pressure: 50 psi
Min Pressure: Ambient

Max Temperature: Ambient
Min Temperature: -320 F

NAME		DATE		TITLE	
DRAWN	M. Hitt	10/21/10		Nitrogen Bath	
CHECKED					
ENG APPR					
MGR APPR					
UNLESS OTHERWISE SPECIFIED DIMENSIONS ARE IN INCHES ANGLES $\pm 0.5^\circ$				SIZE	DWG NO
2 PL ± 0.03 3 PL ± 0.005				B	PRC-5093-003
				FILE NAME	Bath_update.dft
				SCALE	WEIGHT: SHEET 1 OF 1
SOLID EDGE UGS - The PLM Company					
REV					

REVISION HISTORY		
REV	DESCRIPTION	DATE

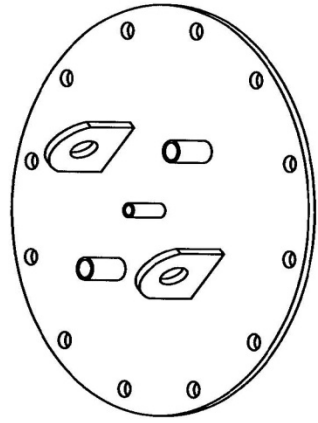
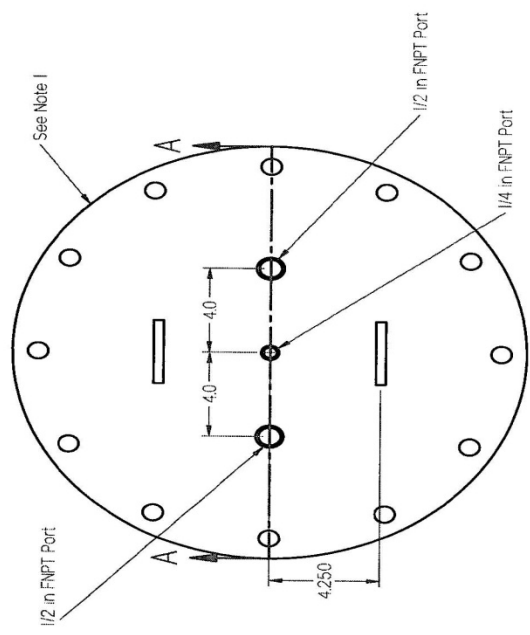

Notes:
 1. Blind Size and Hole Pattern to Match Flange PIN PRC-5093-003

Material: Stainless Steel

Operating Conditions
 Max Pressure: 50 psi
 Min Pressure: Ambient

Max Temperature: Ambient
 Min Temperature: -320 F

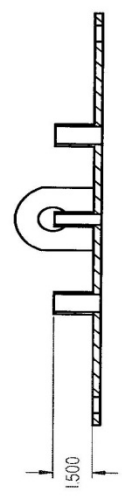

SECTION A-A

NAME		DATE	
DRAWN	M.H.H.	10/2/10	
CHECKED			
ENG APPR			
MGR APPR			
SOLID EDGE			
UGS - The PLM Company			
TITLE			
Nitrogen Bath Lid			
UNLESS OTHERWISE SPECIFIED		SIZE	DWG NO
DIMENSIONS ARE IN INCHES		B	PRC-5093-004
ANGLES ±0.5°		FILE NAME	Lid_Update.dft
2 PL ±0.03 3 PL ±0.005		SCALE	WEIGHT:
			SHEET 1 OF 1

GENERAL CONDITIONS

1. **Award:** The University of Alabama in Huntsville reserves the right to accept or to reject any or all bids and is not necessarily bound to accept the lowest bid if that bid is contrary to the best interest of the University. In making an award, intangible factors such as bidder's service, integrity, facilities, equipment, reputation, and past performance will be weighed along with the quality displayed in the samples submitted. Bids may be awarded either item by item, in products groups, or all or none, whichever appears to be in the best interest of the University. The University reserves the right to waive any or all formalities.
2. **Bid Withdrawal:** No bids may be withdrawn without approval from The University of Alabama in Huntsville Procurement Services. Any requests for withdrawal must be in writing to Procurement Services within five (5) days after opening date with justification for reason of withdrawal. More than two (2) such requests could result in removal from our bid list. No bid may be withdrawn after the issuance of purchase order. If a withdrawal is made after the purchase order is issued, the vendor will be considered in default. Refer to "Default of Contractor".
3. **Prices and Payment Terms:** Bidders should quote applicable cash discounts. The University will not take into consideration in bid evaluation any cash discount of less than thirty (30) days duration. However, we will take advantage of all discounts for which we are eligible. Identify these discounts in your bid response. Bids containing "payment in advance" or "COD" requirements may be rejected.
4. **Applicable Law:** It is agreed this quotation is valid to the extent that it does not violate the constitution or the laws of the State of Alabama.

Bidder represents and warrants that all article and services covered by this bid meet or exceed the safety standards established and promulgated under the Federal Occupational Safety and Health Act of 1970, No. 2006, and its regulations in effect or proposed as of the date of this bid.

The furnishing of materials, supplies, equipment or service to The University of Alabama in Huntsville under this purchase order, contract, solicitation for bids, or construction specification constitutes assurance by the vendor or contractor of his compliance with applicable provisions of and pertinent regulations promulgated under Executive Order 11246, date September 28, 1965 issued by the President of the United States of America, and Public Law 88-352, 88th Congress, the "Civil Rights Act of 1964".

5. **Non-Collusion:** Any agreement or collusion among bidders or prospective bidders in restraint of freedom of competition, by agreement to bid at a fixed price or to refrain from bidding, or otherwise, shall render the bids of such bidders void. Each bidder certifies that he has not been a party to such an agreement by signing this bid.
6. **New Products:** Unless specifically called for in the bid, all products for purchase must be new, never previously used, and the current model and/or packaging. No remanufactured, demonstrator, used, or irregular product will be considered for purchase unless otherwise specified in the bid. The manufacturer's standard warranty will apply unless otherwise specified in the bid. All requests should be supplied complete, ready to be installed, including all cabling and connectors where applicable.
7. **Bonds:** Bid and performance security bond, when required will be indicated.
8. **Bid Submission:** Failure to submit a bid on the official UAHuntsville form provided for that purpose shall be a cause for rejection of the bid. Return of the complete document is required. Modification of or additions to any portion of the solicitation may be cause for rejection of the bid; however, UAHuntsville reserves the right to decide, on a case by case basis, in its sole discretion, whether or not to reject such a bid as non-responsive.

All information shall be entered in ink or typewritten in the appropriate space on the form. Mistakes may be crossed out and corrections inserted before submission of your bid. Corrections shall be initialed in ink by the person signing the bid.

All bids must be signed. Failure to do so will result in rejection of bid.

9. **Delivery:** Time of delivery shall be stated as the number of calendar days following receipt of the order by the vendor, to receipt of the goods by The University of Alabama in Huntsville.

Delivery time may be a criterion in awarding bids. Specify earliest possible delivery after receipt of order.

Failure to deliver within the time vendor specified in the bid will constitute a default and may cause cancellation of the contract. Refer to "Default of Contractor".

All prices quoted are to be F.O.B. delivered to The University of Alabama in Huntsville, Central Receiving Building, 301 Sparkman Drive, Huntsville, Alabama, 35899 (unless another F.O.B. point is stated by the University on bid form). The successful bidder must assume all responsibility for damage in transit. When installation is required, it will be stated. If you are not quoting a delivered price, indicate your shipping point, and provide shipping cost for evaluation purposes.

10. **Bid Terms:** Show unit prices, extensions, and total price. In the event of a discrepancy between the unit price and the extension, the unit price shall govern. Bids shall remain firm for minimum thirty (30) days from date of bid opening and any exception must be clearly stated.
11. **Bid Opening:** Bidders may attend the bid opening, but no information or opinions concerning the ultimate award will be given at the bid opening or during the evaluation process. After the public opening of this bid, the results will not be available to bidders not attending the opening until after an award is made. Bid tabulations can be reviewed by accessing Procurement Services website at <http://www.uah.edu/admin/bussvcs>. Click on "Vendors" then "Bid Award".
12. **Bids are Public Record:** All bids become a matter of public record at bid award. The University accepts no responsibility for maintaining confidentiality of any information submitted with bid whether labeled confidential or not.
13. **Standards of Quality:** When a material, article or piece of equipment is identified in these specifications by reference to manufacturer's or vendor's name, trade name, catalog and stock numbers, etc., it is intended merely to establish a standard; and, any material, article or equipment of other manufacturer and vendor which will perform equally the duties imposed by the general design, provided the material, article, or equipment proposed, is in the opinion of the Purchasing Agent of equal substance and function. It shall not be purchased or installed by the contractor without the Purchasing Agents' written approval.

The bidder is responsible to clearly and specifically indicate the product being offered and to provide sufficient descriptive literature, catalog cuts and technical detail to enable UAHuntsville to determine if the product offered meets the requirements of the invitation. Normally in competitive sealed bidding only the information furnished with the bid will be considered in the evaluation. Failure to furnish adequate data for evaluation purposes may result in declaring a bid nonresponsive. Unless the bidder clearly indicates in its bid that the product offered is an "Equal" product, such bid will be considered to offer the brand name product referenced in the invitation. The University of Alabama in Huntsville will be sole judge of EQUAL items bid.
14. **Vendor Authorization:** Vendor must be an authorized distributor/agent to sell products proposed in this bid request. When it is deemed to be in the best interest of the University, Procurement Services may request an on-site premise visit to examine the facility.
15. **Default of Contractor:** Where the University has determined the contractor to be in default, the University reserves the right to purchase any or all products or services covered by the contract on the open market and to charge the contractor with cost in excess of the contract price. Until such assessed charges have been paid, no subsequent bid from the defaulting contractor will be considered.
16. **Fiscal Funding Clause:** The continuation of this contract is contingent upon the appropriation of funds to fulfill the requirements of the contract by the legislature. If the legislature fails to appropriate sufficient monies to provide the continuation of a contract, the contract shall terminate on the date of the beginning of the first fiscal year for which funds are not appropriated.
17. **Contract Cancellation:** Procurement Services has the right to cancel any contract, in accordance with Purchasing Rules and Regulations, for cause, including, but not limited to, the following: (1) failure to deliver within the contract; (2) failure of the product or service to meet specifications, conform to sample quality, or to be delivered in good condition; (3) misrepresentation by the contractor; (4) fraud, collusion, conspiracy, or other unlawful means of obtaining any contract with the state; (5) conflict of contract provisions with constitutional or statutory provisions of state or federal law; and (6) any other breach of contract.
18. **Warranties:** Should merchandise described on this bid contain a manufacturer's warranty, bidders must state the warranty terms in the space provided on the bid. Bids offered for merchandise when no warranty applies must clearly state: "NO WARRANTY COVERAGE". Warranty information may be criteria in making this award. Failure of bidders to furnish this data may cause rejection of the complete bid as being non-responsive.
19. **Disclosure Statement:** The successful bidder will be required to file with Procurement Services a disclosure statement of relationship between contractors/grantees and employees/officials of the University. This form must be completed prior to issuance of the Purchase Order by The University of Alabama in Huntsville.

Note: In order for an alternate bid to be considered, bidders must supply current catalogs or brochures, including pictorials and specifications.

Please indicate your company classification by circling the appropriate initial: Small Business (**SB**), a Small Disadvantaged Business (**SD**), a Black Small Disadvantaged Business (**BD**), a Woman-Owned Small Business (**WB**), a Woman-Owned Small Disadvantaged Business (**WD**), a Black Woman-Owned Small Disadvantaged Business (**BW**), a Large Business (**LB**), an Individual (**IN**), Educational (**ED**), Non-Profit (**NP**), a Labor Surplus Area Concern (**LS**), Disabled Veteran-Owned Small Business (**DV**), Veteran-Owned Small Business (**VS**), Historically Underutilized Business Zone (**UZ**), or a Governmental Agency (**GV**).

F.O.B. Point	TERMS	WARRANTY
UAHUNTSVILLE DESTINATION		
ESTIMATED DELIVERY	YOUR REFERENCE NO.*	QUOTATION EFFECTIVE UNTIL

* Your company reference number, if applicable with this bid quotation.

Certification Pursuant To Act No. 2006-557

Alabama Law (Section 41-4-116, Code of Alabama 1975) provides that every bid submitted and contract executed shall contain a certification that the vendor, contractor, and all of its affiliates that make sales for delivery into Alabama or leases for use in Alabama are registered, collecting, and remitting Alabama state and local sales, use, and/or lease tax on all taxable sales and leases into Alabama. By submitting this bid, the bidder is hereby certifying that they are in full compliance with Act No. 2006-557, they are not barred from bidding or entering into a contract pursuant to 41-4-116, and acknowledges that the awarding authority may declare the contract void if the certification is false.

COMPANY NAME (TYPE OR PRINT)

TELEPHONE NUMBER

SIGNER'S NAME (TYPE OR PRINT)

FAX NUMBER

EMAIL ADDRESS

SIGNATURE

DATE

The University of Alabama in Huntsville prohibits the installation of asbestos on its campus. Suppliers and contractors will not supply any equipment, material, or supplies, which contain asbestos without prior written approval.

Failure to designate Bid Number and Opening Date on the outside of your sealed envelope containing your bid and more than one bid submitted in this envelope will result in a "No Bid" response in accordance with Alabama Competitive Bid Law 41-16-24 sub-part b.

The University of Alabama in Huntsville will not accept faxed bids.

Any product that fails to meet the specifications, performance requirements or compatibility requirements will be rejected and returned to the vendor at no cost to the University.

**DISCLOSURE STATEMENT OF
RELATIONSHIP BETWEEN CONTRACTORS/GRANTEES AND
EMPLOYEES/OFFICIALS OF UA/UAB/UAHuntsville/UAS
(THE "UNIVERSITY OF ALABAMA SYSTEM")**

1. Contract # **B002042**

2. Name of Contractor/Grantee _____
 Address _____

 Phone _____

3. Nature of contract/grant
 _____ **FABRICATED BATH AND TEST SKID with LIDS** _____

4. Does the contractor/grantee have any relationship with an employee or official of the University, or a family member of such employee or official, that will enable such employee or official, or his/her family member, to benefit from this contract/grant? If so, please state the names, relationships, and nature of the benefit.

(For employees of the University, family members include spouse and dependants. For members of the Board of Trustees (officials), family members include spouse, dependants, adult children or their spouses, parents, in-laws, siblings, and their spouses.)

Certification Pursuant To Act No. 2006-557

Alabama Law (Section 41-4-116, Code of Alabama 1975) provides that every bid submitted and contract executed shall contain a certification that the vendor, contractor, and all of its affiliates that make sales for delivery into Alabama or leases for use in Alabama are registered, collecting, and remitting Alabama state and local sales, use, and/or lease tax on all taxable sales and leases into Alabama. By submitting this bid, the bidder is hereby certifying that they are in full compliance with Act No. 2006-557, they are not barred from bidding or entering into a contract pursuant to 41-4-116, and acknowledges that the awarding authority may declare the contract void if the certification is false.

This disclosure form will be available for public inspection upon request.

The above information is true and accurate, to the best of my knowledge.

Signature of Authorized Agent

Date

This form must be completed and returned before any contract(s) will be issued by the University.